

Relay S 2PH

from 30- 40A

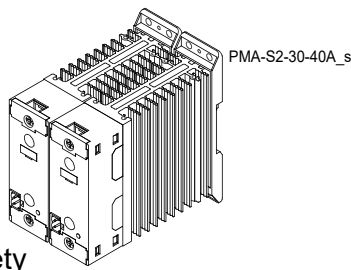

Important warnings for safety

	This icon is present in all the operational procedures where the Improper operation may result in serious personal injury or death by Electrical Shock Hazard Symbol (a lightning bolt in a triangle) precedes an electric shock hazard CAUTION or WARNING safety statement.
	Warning or Hazard that needs further explanation than the label on unit can provide. Consult User's Guide for further information.
	Unit is compliant with European Union directives. See Declaration of Conformity for further details on Directives and Standards used for Compliance.
	If available, unit is a Listed device per Underwriters Laboratories. It has been investigated to ANSI/UL® 508 standards for Industrial Control Switches and equivalent to CSA C22.2 #14. For more detail search for File E505847 on www.ul.com
	ESD Sensitive product, use proper grounding and handling techniques when installing or servicing product.
	Do not throw in trash, use proper recycling techniques or consult manufacturer for proper disposal.

Safety notes

WARNING! To avoid damage to property and equipment, injury and loss of life, adhere to applicable electrical codes and standard wiring practices when installing and operating this product. Failure to do so could result in damage, injury and death.

AVERTISSEMENT! Pour éviter d'endommager la propriété et l'équipement, les blessures et la perte de vie, respecter les codes électriques en vigueur et les pratiques de câblage standard au moment de l'installation et de l'utilisation de ce produit. Dans le cas contraire, cela peut entraîner la mort, des blessures graves ou des dommages.

WARNHINWEIS! Um Sach- und Personenschäden, Verletzungen und den Verlust von Leben zu vermeiden, halten Sie sich bei der Installation und dem Betrieb dieses Produkts an die geltenden Elektrovorschriften und Standardverfahren für die Verdrahtung. Andernfalls kann es zu Schäden, Verletzungen und Tod führen.

WARNING! All service including inspection, installation, wiring, maintenance, troubleshooting, fuse or other user serviceable component replacement must be performed only by properly qualified personnel. Service personnel must read this manual before proceeding with work. While service is being performed un-qualified personnel should not work on the unit or be allowed in the immediate vicinity.

AVERTISSEMENT! Tous les services, y compris l'inspection, l'installation, le câblage, l'entretien, le dépannage, le remplacement de fusibles ou d'autres composants pouvant être réparés par l'utilisateur, doivent être effectués uniquement par un personnel d'entretien qualifié. Le personnel de service doit lire ce manuel avant d'effectuer tout travail. Pendant que l'entretien est exécuté, tout personnel non qualifié ne doit effectuer de travail sur l'appareil ni se trouver à proximité.

WARNHINWEIS! Alle Wartungsarbeiten, einschließlich Inspektion, Installation, Verdrahtung, Wartung, Fehlersuche, Sicherung oder anderer vom Benutzer zu wartenden Komponenten, dürfen nur von qualifiziertem Fachpersonal durchgeführt werden. Das Wartungspersonal muss dieses Handbuch lesen, bevor es mit der Arbeit fortfährt. Während der Wartung darf nicht qualifiziertes Personal nicht an diesem Gerät oder in unmittelbarer Nähe arbeiten.

WARNING! When in use the power controller is connected to dangerous voltages. Do not remove the protective covers without first disconnecting and preventing power from being restored while servicing the unit.

AVERTISSEMENT! Au moment de l'utilisation, le régulateur de puissance est connecté à des tensions dangereuses. Ne retirer aucun couvercle de protection sans d'abord débrancher l'appareil et ainsi empêcher l'alimentation d'être rétablie pendant l'entretien.

WARNHINWEIS! Während dem Betrieb ist der Thyristor Leistungssteller an gefährlichen Spannungen angeschlossen. Entfernen Sie die Schutzabdeckungen nicht, ohne vorher die Spannungsversorgung unterbrochen zu haben und die Anlage gegen Wiederherstellung der Stromversorgung zu sichern, während Sie das Gerät warten.

WARNING! Do not use in aerospace or nuclear applications.

AVERTISSEMENT! Ne pas utiliser pour les applications aérospatiales ou nucléaires.

WARNHINWEIS! Nicht in Luft-, Raumfahrt- oder Nuklearanwendungen verwenden.

WARNING! Electric Shock Hazard: when the power controller has been energized, after shutting off the power, wait at least one minute for internal capacitors to discharge before commencing work that brings you in to contact with power connections or internal components.

AVERTISSEMENT! Risque de décharges électriques: lorsque le régulateur de puissance est mis sous tension, après avoir été éteint, attendre au moins une minute pour que les condensateurs internes se déchargent avant de commencer tout travail incluant le contact avec les connexions électriques ou les composants internes.

WARNHINWEIS! Stromschlaggefahr: Warten Sie nach dem Ausschalten des Leistungsstellers mindestens eine Minute, bis sich die internen Kondensatoren entladen haben, bevor Sie mit Arbeiten beginnen, die Sie mit den elektrischen Anschlüssen oder internen Komponenten in Kontakt kommen.

WARNING! The installation must be protected by electromagnetic circuit breakers or by fuses. The semiconductor fuses located inside the power controller are classified for UL as supplementary protection for semiconductor devices. They are not approved for branch circuit protection.

AVERTISSEMENT! L'installation doit être protégée par des disjoncteurs électromagnétiques ou des fusibles. Les fusibles pour semi-conducteurs situés à l'intérieur du régulateur de puissance sont classés UL comme protection supplémentaire pour les dispositifs pour semi-conducteurs. Ils ne sont pas approuvés pour la protection des circuits de dérivation.

WARNHINWEIS! Die Installation muss durch elektromagnetische Schutzschalter oder Sicherungen abgesichert sein. Die Halbleitersicherungen, die sich innerhalb des Leistungsstellers befinden, sind als zusätzlicher Schutz für Halbleitervorrichtungen für UL klassifiziert. Sie sind nicht für den Nebenstromkreischutz (branch circuit protection) zugelassen.

CAUTION: Install an appropriately sized RC filter across contactor coils, relays and other inductive loads.

ATTENTION: Installer un filtre RC de dimensions appropriées sur les bobines du contacteur, les relais et autres charges par induction.

VORSICHT: Installieren Sie einen geeigneten RC-Filter an den Schützspulen, Relais und anderen induktiven Lasten.

CAUTION: The thyristor units here described have been designed for use with sinusoidal networks with nominal frequency 50-60 Hz. Any application with NON-SINUSOIDAL, distorted or disturbed networks could compromise the correct operation of the unit.

ATTENTION: Les unités de thyristors décrites ici ont été conçues pour être utilisées avec des réseaux sinusoïdaux d'une fréquence nominale de 50 à 60 Hz. Toute application utilisant des réseaux NON SINUSOÏDAUX, déformés ou perturbés peut compromettre le bon fonctionnement de l'appareil.

VORSICHT: Die hier beschriebenen Thyristor-Einheiten sind für den Einsatz in Sinusnetzen mit einer Nennfrequenz von 50 bis 60 Hz ausgelegt. Jede Anwendung mit NICHT SINUSFÖRMIGER Wellenform, verzerrten oder gestörten Netzwerken kann den korrekten Betrieb des Geräts beeinträchtigen.

NOTE: The nominal current is specified for ambient temperatures at or below 40° C. Ensure the application design allows for adequate cooling of each power controller. The power controller must be mounted vertically. The cooling design must prevent air heated by one power controller from causing power controllers mounted above to exceed the ambient operating temperature limit. When power controllers are mounted side by side allow a minimum spacing of 15mm between them.

REMARQUE: Le courant nominal est précisé pour des températures ambiantes égales ou inférieures à 40°C. S'assurer que la conception de l'application permette le refroidissement adéquat de chaque régulateur de puissance. Le régulateur de puissance doit être monté verticalement. La conception de refroidissement doit empêcher l'air chauffé par le régulateur de puissance de dépasser la limite de température de fonctionnement ambiante de la part des régulateurs de puissance montés au-dessus. Lorsque les régulateurs de puissance sont montés côte à côte, il faut conserver un espacement minimal de 15 mm entre les deux.

HINWEIS! Der Nominalstrom ist für Umgebungstemperaturen von maximal 40° C spezifiziert. Stellen Sie sicher, dass in Ihrer Anwendung eine ausreichende Kühlung für jeden Leistungssteller ermöglicht. Der Leistungssteller muss vertikal montiert werden. Das Kühlkonzept muss verhindern, dass die von einem Leistungssteller erwärmte Luft dazu führt, dass die darüber montierten Leistungssteller die zulässige Umgebungstemperatur überschreiten. Wenn Leistungssteller nebeneinander montiert werden, muss ein Mindestabstand von 15 mm eingehalten werden.

NOTE: Use only copper cables and wires rated for use at 90°C or greater.

REMARQUE: N'utiliser que des cables et des fils en cuivre pour l'utilisation à 90°C ou plus.

HINWEIS! Verwenden Sie nur Kupferkabel und Leitungen, die für den Gebrauch bei 90° C oder höher ausgelegt sind.

1. Identification of the unit

Caution: Before to install, make sure that the Thyristor unit have not damages. If the product has a fault, please contact the dealer from which you purchased the product.



The identification's label give all the information regarding the factory settings of the Thyristor unit, this label is on the side of the unit. Verify that the product is the same thing as ordered.

2. Technical Specifications

2.1 General features

Cover and Socket material:	PolymericV2
Mounting:	DIN bar (thickness type 1mm Max)
Utilization Category:	AC-51 AC-55b
IP Code:	20
Method of Connecting:	Load in Delta, Load in Star
Delay switch ON/OFF time:	1/2 Period Max

2.2 Input features

Logic input SSR: 5+30Vdc 18mA Max (ON ≥5Vdc OFF <4Vdc)

2.3 Output features (power device)

Nominal current in continuous service:	See order code
Max peak current (10ms):	360A for unit type 030 540A for unit type 035 700A for unit type 040
Nominal Voltage range Ue:	24+600V
Repetitive peak reverse voltage Uimp:	1200V (480V) 1600V (600V)
Latching current:	250mA
Leakage current:	15mA eff
FUSE I²T value suggested at 500Vac tp=10msec:	525 A²s for unit type 030 1260 A²s for unit type 035 1260 A²s for unit type 040
Frequency range:	47+70Hz
Power loss (I=Inom):	76W for unit type 030 88W for unit type 035 100W for unit type 040
Isolation Voltage Ui:	2500Vac

2.4 Environmental installation conditions

Ambient temperature	0-40°C (32-104°F) at nominal current. Over 40°C use the derating curve.
Storage temperature	-25°C to 70°C, -13°F to 158°F
Installation place	Don't install at direct sun light, where there are conductive dust, corrosive gas, vibration or water and also in salty environmental.
Altitude	Up to 1000 meter over sea level. For higher altitude reduce the nominal current of 2% for each 100m over 1000m
Humidity	From 5 to 95% without condense and ice
Pollution Level	Up to 2nd Level ref. IEC 60947-1 6.1.3.2

2.5 Derating Curve

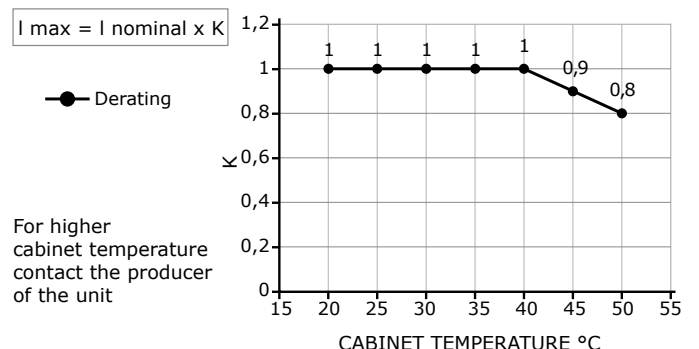

3. Installation

Before to install, make sure that the Thyristor unit have not damages.

If the product has a fault, please contact the dealer from which you purchased the product. Verify that the product is the same thing as ordered.

The Thyristor unit must be always mounted in vertical position to improve air cooling on heat-sink.

Maintain the minimum distances in vertical and in horizontal as represented. When more unit has mounted inside the cabinet maintain the air circulation like represented in figure. Sometimes is necessary installing a fan to have better air circulation.

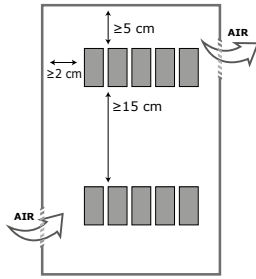

3.1 Dimensions and Fixing holes

Size: SR4

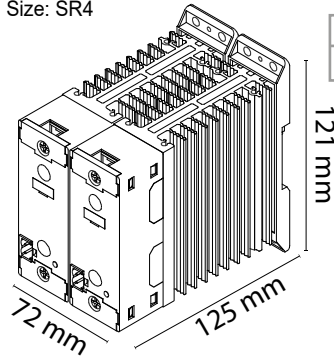

Weight
0,88Kg

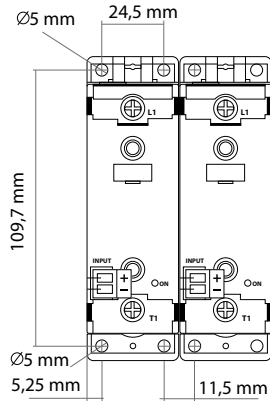

4. Wiring instructions

The Thyristor unit could be susceptible to interferences lost by near equipments or by the power supply, for this reason in accord to the fundamental practices rules is opportune take some precautions:

- The coil contactor, the relays and other inductive loads must be equipped with opportune RC filter.
- Use shielded bipolar cables for all the input and output signals.
- The signal cables must not be near and parallel to the power cables.
- Local regulations regarding electrical installation should be rigidly observed. Use copper cables and wires rated for use at 90°C only.

4.1 Power cable torque (suggested)

Type	Connector Type	Torque Lb-in (N-m)	Wire Range mm ² (AWG)	MAX Current Terminals	Wire Terminals UL Listed (ZMVV)
030 035 040	Screw M5	26.6 (3.0)	1.5-10 (16-8)	50A	Rigid / Flexible Spade Terminal

4.2 Cable dimensions of the Command Terminals

0.5 mm² (AWG 18)

4.3 Cable dimensions of the Earth (suggested)

6 mm² (AWG 10)

4.4 Connection Diagram for Single-phase

Note:

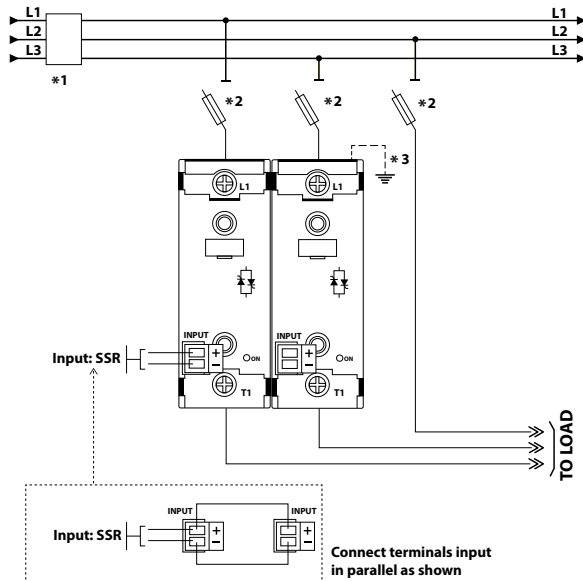

*1 A suitable device must ensure that the unit can be electrically isolated from the supply, this allows the qualified people to work in safety.

*2 The thyristor unit must be protected by extrarapid fuses (optional). The Fuses must have I²t 20% less than thyristor's I²t. The warranty of thyristor is null if no proper fuses are used (see technical data).

*3 The heat-sink must be connected to the earth.

5. External Fuse (not included)

The thyristor unit without IFH option (Internal Fuse + Fuse-Holder), must be protected by fuses against short circuit.

The Fuses must have I²t 20% less than thyristor's I²t. The warranty of thyristor is null if no proper fuses are used.

Type	Fuse + Fuse-Holder Order Code	Fuse Code Spare Part	Current (ARMS)	I ² T at 500Vac* (A ² sec.)	Vac
030	FFH1451/40A	FU1451/40A	40	525	660
035	FFH1451/50A	FU1451/50A	50	1260	660
040	FFH1451/50A	FU1451/50A	50	1260	660

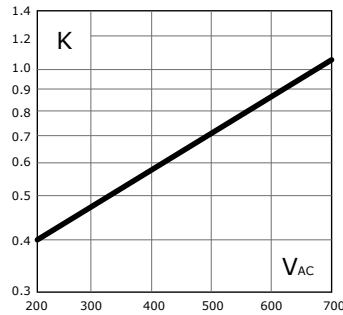

⚠ Caution: High speed fuses are used only for the thyristor protection and can not be used to protect the installation.

⚠ Caution: The warranty of thyristor is null if no proper fuses are used. See table.

5.1 External Fuse-holder Dimension (not included)

6. Trouble shooting

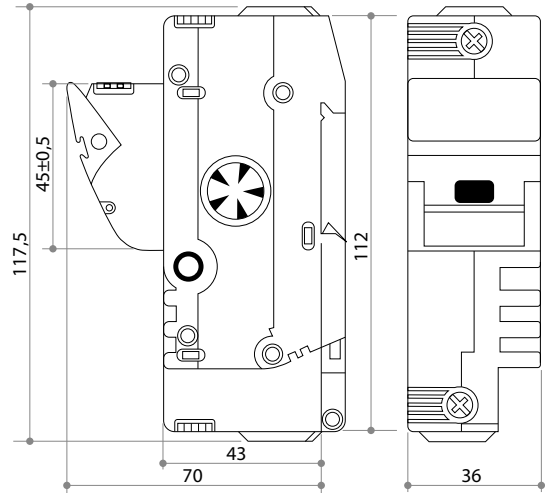

Small problems sometimes can be solved locally with the help of the below tab of trouble shooting.

If you don't succeed, contact us or your nearest distributor.

Symptom	Indication on front unit	Possible reasons of the symptom	Actions
Load current doesn't flow	Green LED (ON) light OFF	<ul style="list-style-type: none"> • No input signal • Reversed polarities of input signal 	<ul style="list-style-type: none"> • Give input signal • Reverse the input signal polarity
	Green LED (ON) light ON	<ul style="list-style-type: none"> • No voltage power • Fuse failure • Load failure • Thyristor failure 	<ul style="list-style-type: none"> • Check the wiring • Change the fuse • Check the load • Change the module
Load current flow also without input signal	Green LED (ON) always light OFF	<ul style="list-style-type: none"> • Wrong wiring • SCR short circuit 	<ul style="list-style-type: none"> • Check the wiring • Change the module

DOWNLOAD THE FULL MANUAL FROM: www.west-cs.co.uk

Contact

UK

Email: enquiries@west-cs.com
 Website: www.west-cs.co.uk
 Telephone: +44 (0)1273 606271

Germany

Email: de@west-cs.com
 Website: www.west-cs.de
 Telephone: +49 561 505 1307

France

Email: fr@west-cs.com
 Website: www.west-cs.fr
 Telephone: +33 171 84 1732



West Control Solutions is part of the Fortive Corporation. Specifications are subject to change without notice, as a result of our continual development and improvement, E&OE.

SM-RS234-1-UK-1904